

USG BORAL ENSEMBLE™ ACOUSTICAL PLASTERBOARD CEILING



TECHNICAL MANUAL
(DESIGN GUIDE)

USG BORAL 
INNOVATION INSPIRED BY YOU.™

[USGBoral.com](https://www.usgboral.com)

Plasterboard

Ceilings

Interior Finishes

Metal Framing

Substrates

© 2018 USG BORAL. All rights reserved. The trademarks USG BORAL, INNOVATION INSPIRED BY YOU, ENSEMBLE, EASYSET and PLUS 3 are trademarks of USG Boral Building Products or one or more of its affiliates. SHEETROCK and Donn are trademark owned by United States Gypsum Company and used under license.

DG_C(OC)_EM_1018

OVERVIEW

The USG Boral Ensemble™ Acoustical Plasterboard Ceiling is a new solution for interior ceilings that combines the seamless look of plasterboard with the acoustical properties of tile-and-grid systems. Breakthrough innovations across core USG Boral product technologies come together in one ceiling system to maximise NRC, CAC and LR performance. The bright white finish and monolithic appearance eliminates distracting gridlines. Specify the USG Boral Ensemble™ Acoustical Plasterboard Ceiling, and there is no longer a need to compromise aesthetics for acoustical performance in the spaces you create.

Although aesthetically appealing, hard finishes—such as glass, concrete, stone, wood and plasterboard—reflect sound and make spaces noisy and difficult to hear in. Until now, the cost effective solution for sound control has been a traditional acoustical ceiling tile and grid system. The USG Boral Ensemble™ Acoustical Plasterboard Ceiling is an innovative solution that integrates technologies from our ceiling tile, plasterboard and finishing systems. It installs similar to traditional plasterboard, and can be incorporated into spaces where acoustical ceilings and plasterboard ceilings would normally be used. It can be intermixed with acoustical ceilings in locations where plenum access is needed, and all typical plasterboard trims and fixtures are compatible with the system.



Ensemble™ Acoustical Plasterboard Ceiling in Northern Trust Bank (USA)

BALANCED ACOUSTICS

Sound is created in the form of pressure traveling in waves through any medium, most commonly air. Noise is excessive or unwanted sound. Hard surfaces like stone, glass and wood may be aesthetically pleasing, but are often not the perfect choice because they reflect sound. Too much noise makes it hard to work, learn and relax.

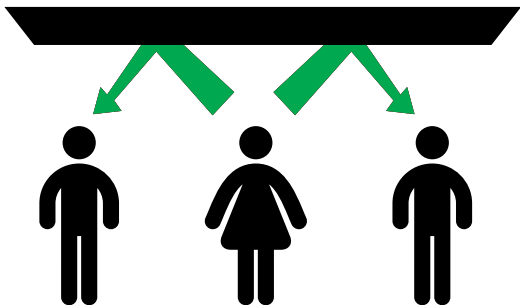
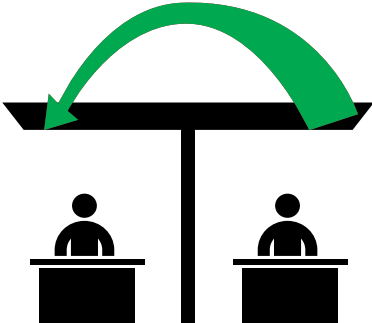
<p>The measures of sound absorption;</p> <ul style="list-style-type: none"> • Noise Reduction Coefficient (NRC), • Sound Absorption Average (SAA) and • Weighted Sound Absorption Coefficient (α_w) 	<p>The measures of over-partition sound insulation;</p> <ul style="list-style-type: none"> • Ceiling Attenuation Class (CAC)
	
<p>NRC, SAA and α_w are single number ratings used to formulate requirements and to describe acoustical properties of sound-absorbing products. NRC & SAA are tested and derived from ASTM C423, α_w is tested and derived from ISO 354 and ISO 11654 respectively. Although the SAA supercedes the NRC, the NRC is reported in order to provide comparison with values reported in the past. Unlike the NRC & SAA which are derived by averaging sound absorption coefficients, α_w uses a curve fitting process. Although more complex to derive, Alpha w is considered to be more representative of how the human ear interprets sound. Shape indicators L,M,H are added to the α_w rating to indicate a prescribed increase in sound absorption in particular frequency ranges; L at 250Hz, M at 500Hz or 1000Hz, H at 2000Hz or 4000Hz. An NRC, SAA or α_w rating of 0 indicates perfect reflection; a rating of 1 indicates perfect absorption. The higher the rating, the shorter the reverberation time in a space.</p>	<p>CAC: Applies to the sound attenuation of acoustical ceilings with a shared plenum between horizontally adjacent spaces.</p> <p>Ceiling Attenuation Class measures how well a material blocks sound transmission. Specifically, Ceiling Attenuation Class is a measure of reduction in sound transmission via plenum path between two adjacent rooms. It is a two pass test, as sound must travel through one ceiling, into the plenum space, and back down through the ceiling into the adjacent room. The performance is expressed in decibel reduction between the two rooms.</p> <p>CAC is tested and derived from ASTM E1414 and ASTM E413 respectively.</p>

A general rule of thumb is that NRC and CAC performance are inversely proportional. The key for balanced acoustics is to develop ceiling systems that perform well in both categories. High-performance ceiling systems with balanced acoustics achieve an NRC of 0.70, and a CAC of 35 or greater, and provide good sound control for many applications.

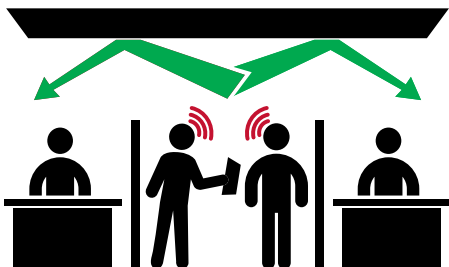

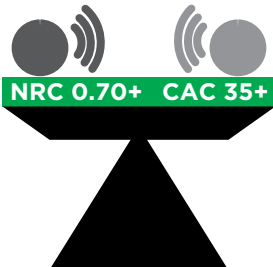

Too much noise makes it hard to concentrate, learn or work.

Typical high performance ceiling achieve NRC of 0.70 and CAC of 35 or greater.

HOW IT WORKS

The USG Boral Ensemble™ Acoustic Plasterboard Ceiling has been engineered to allow sound to pass through while at the same time providing a visual that is similar to painted plasterboard. Sound passes through the finish and into the perforations in the USG Boral Ensemble™ Ceiling Panels. From there, most of the sound pressure is absorbed by the back veil and/or insulation. A portion of the sound is trapped in the plenum space where it dissipates.

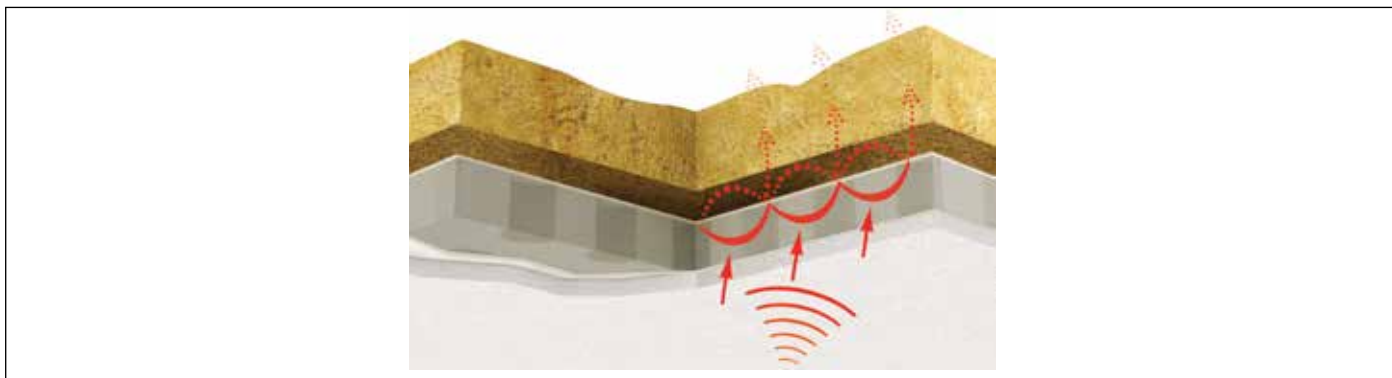

The USG Boral Ensemble™ Spray Applied Finish is acoustically permeable. Sound passes through the finish and perforations where it dissipates above the ceiling.

SYSTEM COMPONENTS

Product	Sizes	Remarks
Rondo Top Cross Rail (PN 128)	Length: 3600mm Height: 38mm	Spaced at 1200mm centres
Rondo Furring Channel (PN 129)	Length: 3600mm Height: 28mm	Spaced at 400mm centres
Rondo Furring Channel Track (for perimeter) (PN 140)	Length: 3000mm	
Rondo TCR and Rod Joiner (PN 2534)		
Rondo TCR to FC Joiner (PN 139)		
Rondo 5mm Soft Galvanised Suspension Rod (PN 121)	Length: 3600mm	Spaced at 1200mm centres
Rondo Stitching Batten (PN MB005)		
50mm-thick 40kg/m³ rock wool	1200mm x 600mm	Packed in slabs
USG Boral Ensemble™ Ceiling Panels	12.5mm x 1200mm x 2400mm	
USG Boral SHEETROCK® Brand Paper Joint Tape	63.5mm x 76.2m or 63.5mm x 152.4m	
USG Boral EasySet™ 20	20kg per bag	
USG Boral SHEETROCK® Lightweight Finishing Joint Compound Plus 3™	17L per pail	
USG Boral Ensemble™ Spray-applied Finish, White	17L per pail	

SYSTEM COMPONENTS

RONDO KEYLOCK SUSPENSION SYSTEM



Rondo Top Cross Rail (PN 128)

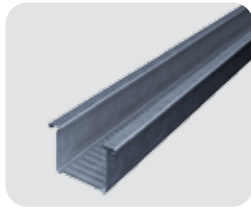

Rondo Furring Channel (PN 129)

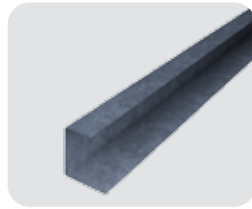

Rondo Furring Channel Track (PN 140)



Rondo Connecting Clip (PN 139)



Rondo Suspension Clip (PN 2534)



Rondo 5mm Soft Galvanised Suspension Rod (PN 121)



Rondo Stitching Batten (PN MB005)

INSULATION

50mm-thick 40kg/m³ rock wool



ENSEMBLE CEILING PANEL SPECIFICATIONS

Feature	Description
Thickness	12.5mm
Pattern	12.0mm diameter round hole
Edge Profile	Recessed edge
Sheet Size	1200mm x 2400mm
Paper Colour	Ivory paper (front)
Veil Colour	White veil (front and back)
Open Area	20%
Mass	7kg/m ² (Note: Perforated and laminated)
Fire Hazard Properties	Non-combustible (BS 476)
TVOCs Emission	Not detected (under SGLS-032 eco-labelling)

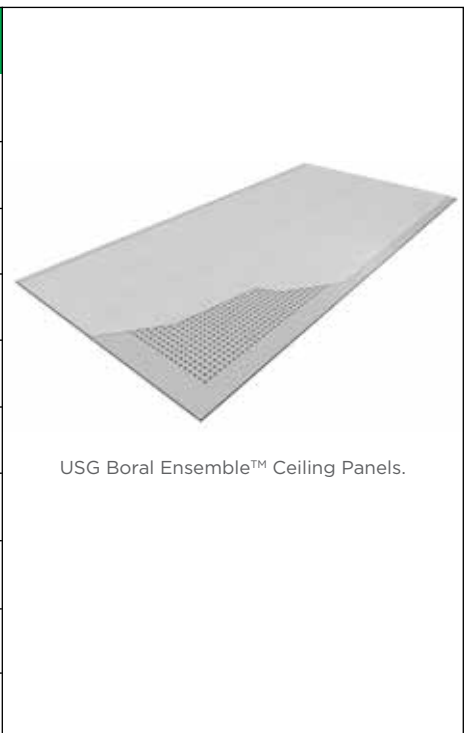



SYSTEM COMPONENTS

FINISHING SYSTEMS

Joint Tape	Name	Size (Width x Length)
	USG Boral SHEETROCK® Brand Paper Joint Tape	63.5mm x 76.2m or 63.5mm x 152.4m

First and Second Coat	Name	Colour	Working Time	Packaging	VOC
	USG Boral EasySet™ 20	Off white	Setting type - 20 minutes working time	20kg bag	Not detected (under SGLS-032 eco-labelling)

Third Coat	Name	Colour	Working Time	Packaging	Coverage
	USG Boral SHEETROCK® Lightweight Finishing Joint Compound Plus 3™	Off white	Setting type - air drying type	17L Pail	38.3L/100m ² of plasterboard

Finishing Coat	Name	Colour	Binder	Coverage	pH	Weight Solids	Packaging
	USG Boral Ensemble™ Spray-applied Finish	White	Water-based acrylic	Approximately 10m ² per 17-liter pail	9.0 to 10.0	55-60%	17-liter pail

DESIGN CONSIDERATIONS

CONSIDER THE SPACE

The USG Boral Ensemble™ Acoustical Plasterboard Ceiling is ideal for simple, flat ceilings without excessive penetrations or recessed light fixtures (enclosed light fittings are recommended for the best result). This is so the perforated field area is maximised and joint finishing and accessories are minimised. Ceilings with multiple terminations, penetrations and flush-mounted fixtures all must be finished with joint compound and which naturally reduces the perforated area. This, in turn, can negatively affect the sound performance.

CONSIDER THE LIGHTING

Understanding the type of lighting source types and illumination direction is crucial when selecting ceiling systems. Light sources that illuminate at oblique angles can magnify imperfections across any surface. This is especially true for ceiling because they are often adjacent to windows, where natural light enters the space obliquely in the morning and evening. It is important to understand the position of the types of lightings below and how it affects the appearance of the ceiling.

Glancing Light

Glancing light is the light that shines across a surface, rather than directly at it. Glancing light casts shadows from minute undulations that would not normally be visible in diffused (non-directional) lighting. While minor surface variations can always be expected (even with a level 5 finish), the appearance of flatness will depend predominantly on the amount of glancing light the surface receives and to some degree, its intensity and direction. Some of the worst instances of glancing light occur with ceiling-mounted unshaded light globes and where windows are located close to ceilings, allowing sunlight to shine across adjacent surfaces. In order to avoid the effects of glancing light, it is important to carefully plan the selection and placement of windows and lighting during the design phase.

Artificial Light

It is recommended that artificial lighting should either be hung below the ceiling surface and fitted with shades, or recessed into the ceiling (i.e. downlights). Positioning of feature lighting, such as spot and flood lights, needs to be planned so that light shining across the ceiling surface is minimised. High output lights are more severe in their effect because they create deeper shadows. Similarly, the whiter the light, the stronger the contrast and the greater the perceived surface variations. Soft, low wattage, diffused lighting provides the most favourable lighting conditions for ceiling surfaces.

Natural Light

The effects of natural glancing light can be exaggerated by late afternoon or early morning sunlight, as well as reflections from adjacent walls, roofs and water features such as swimming pools, canals and waterways. Raked ceiling abutting clerestory windows, and flat ceilings abutting window heads, are likely to be affected. Where a building design cannot be changed, the effects of glancing light can be minimised by using window shades, soft furnishings, curtains, blinds and pelmets.

Note: High intensity halogen floodlights or fluorescent lights should not be used for visual inspection of interior surfaces, as they create unfavourable glancing light conditions.

CONSIDER THE SOUND PERFORMANCE REQUIREMENTS

The USG Boral Ensemble™ Acoustical Plasterboard Ceiling offers quality acoustical performance when high NRC/SAA/ α_w & CAC is needed to meet the project requirements. However, NRC/SAA/ α_w system performance is partially dependent upon plenum space.

USG Boral Ensemble™ Acoustical Plasterboard Ceiling has been laboratory tested with various air gaps to simulate common ceiling plenum depths. The sound absorption performance does vary depending on the plenum depth.

CONSIDER THE PLENUM

Type E mountings as described in ASTM E795 are intended to simulate a suspended ceiling with an open plenum above it. The suffix of the mounting designation is the distance between the exposed face of the specimen and the test surface; ASTM C423 recommends a Type E-400 mounting, and ISO 354 recommends either Type E-200, E-300 or E-400.

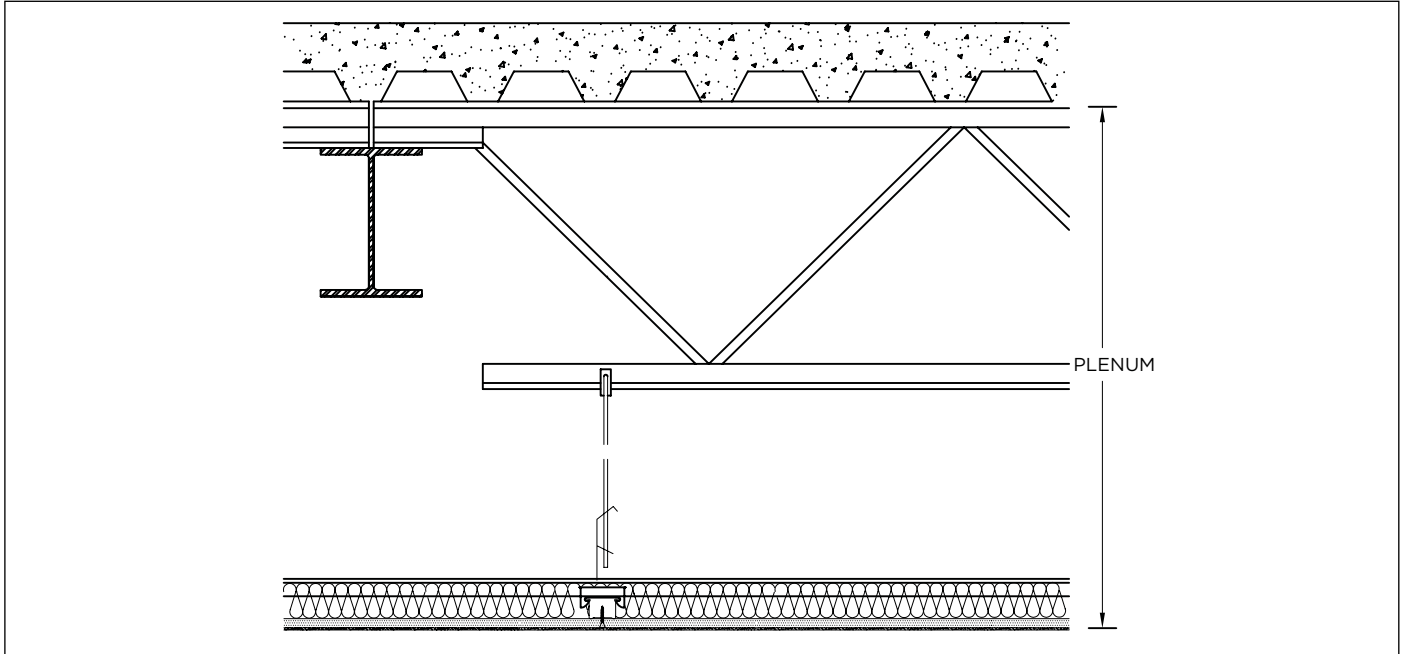

The USG Boral Ensemble™ Acoustical Plasterboard Ceiling provides the best NRC performance when used in applications with a plenum space above.

PERFORMANCE DATA

The USG Boral Ensemble™ Acoustical Plasterboard Ceiling offers high NRC/SAA/ α_w and high CAC performance to meet the project needs.

SOUND ABSORPTION PERFORMANCE RATINGS

Mounting	Insulation	NRC	SAA	α_w	Test Report No.
E-200	50mm rock wool, 40kg/m ³	0.80	0.85	0.80 (L)	ATS17-043-RP026

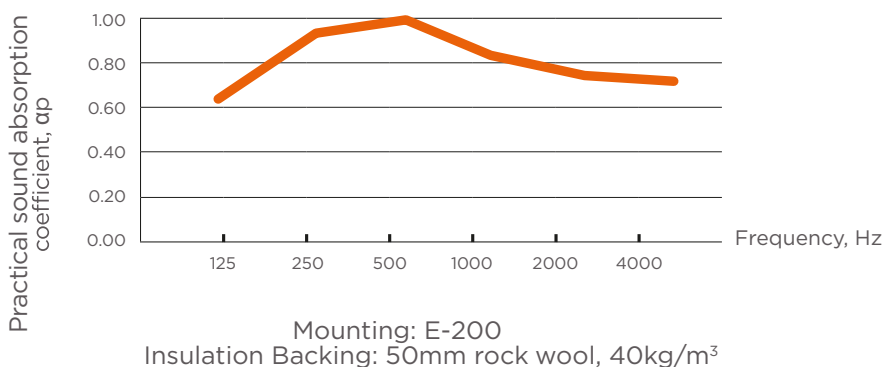

Notes:

1. Tested in accordance with ASTM C423 - 09a 'Standard Test Method' for Sound Absorption and Sound Absorption Coefficients by the Reverberation Room Method.
2. Testing conducted at Acoustic Testing Services Limited (ATSL), Hong Kong - accredited by Hong Kong Accreditation Service (HKAS).
3. α_w derived from ASTM test report.
4. Performance data shown are results of actual tests conducted by USG Boral.

PERFORMANCE DATA

OVER-PARTITION PERFORMANCE RATINGS

Insulation	CAC	Test Report No.
None	34	STR18011-6
50mm rock wool 40kg/m ³	48	STR18011-4

Notes:

1. Tested in accordance with ASTM E1414 'Standard Test Method' for Airborne Sound Attenuation Between Rooms Sharing a Common Ceiling Plenum.
2. Testing conducted at Supreme NAP Acoustics (Huizhou) Ltd. Laboratory, China - accredited by China National for Conformity Assessment (CNAS).

DETAILS

USG BORAL ENSEMBLE™ ACOUSTICAL PLASTERBOARD CEILING

The USG Boral Ensemble™ Acoustical Plasterboard Ceiling has the appearance of plasterboard yet performs like an acoustical ceiling. Installation is very much like a plasterboard ceiling system. Then the highly engineered USG Boral Ensemble™ Ceiling Panels are screw-attached to the bottom of the Suspension System framing members. Joints are finished like plasterboard. Then an acoustically transparent coating is applied to the surface as the final decoration.

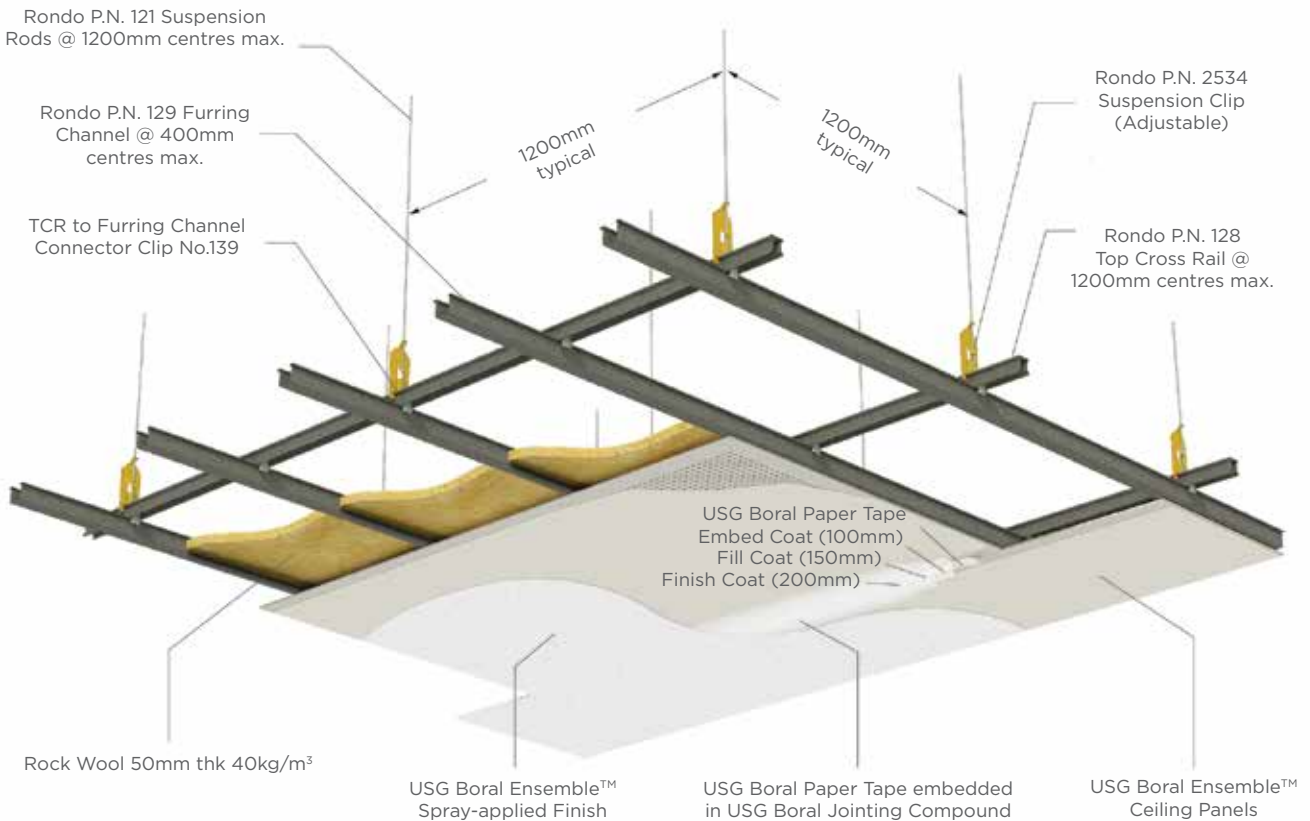

DETAILS

RONDO KEY-LOCK® SUSPENSION SYSTEM

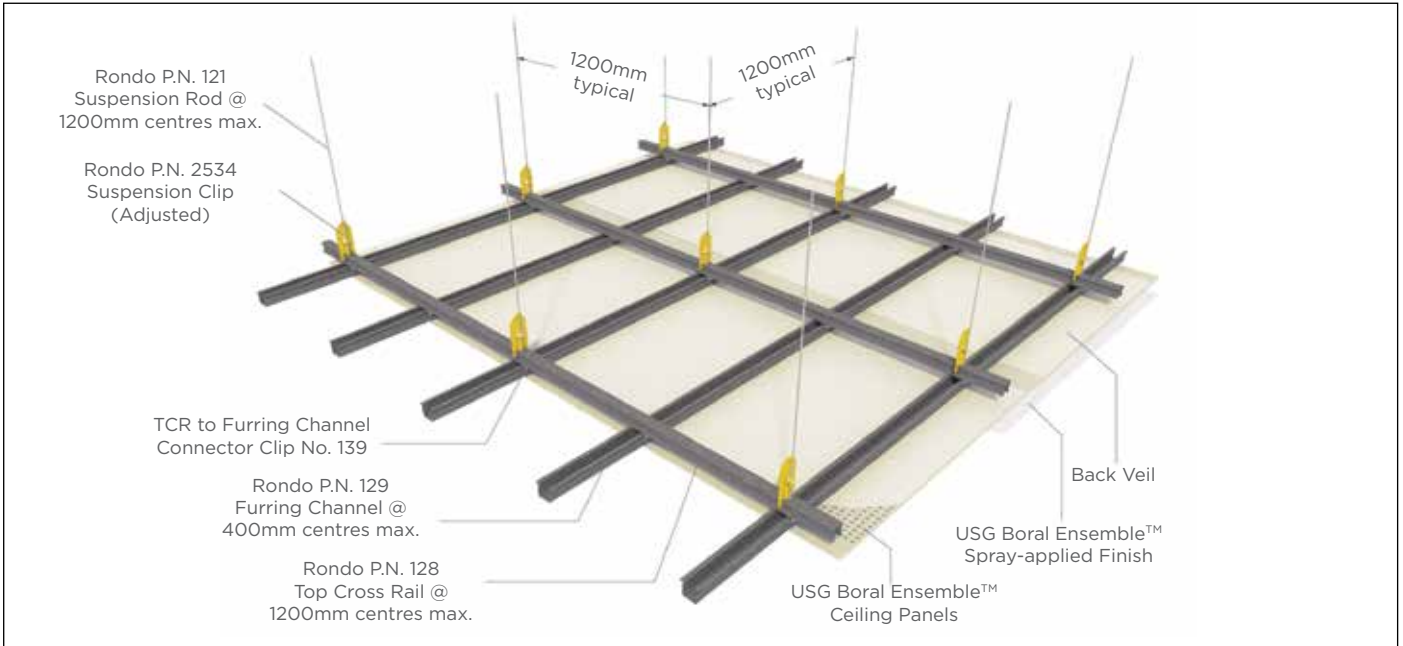

Note: Insulation backing not shown for clarity. Refer to Technical Manual (Installation Guide) for details.

TYPICAL METAL FRAMING LAYOUT

USG Boral Ensemble™ Acoustical Plasterboard Ceiling integrates with lights, diffusers and other ceiling utilities the same way that drywall ceilings do.

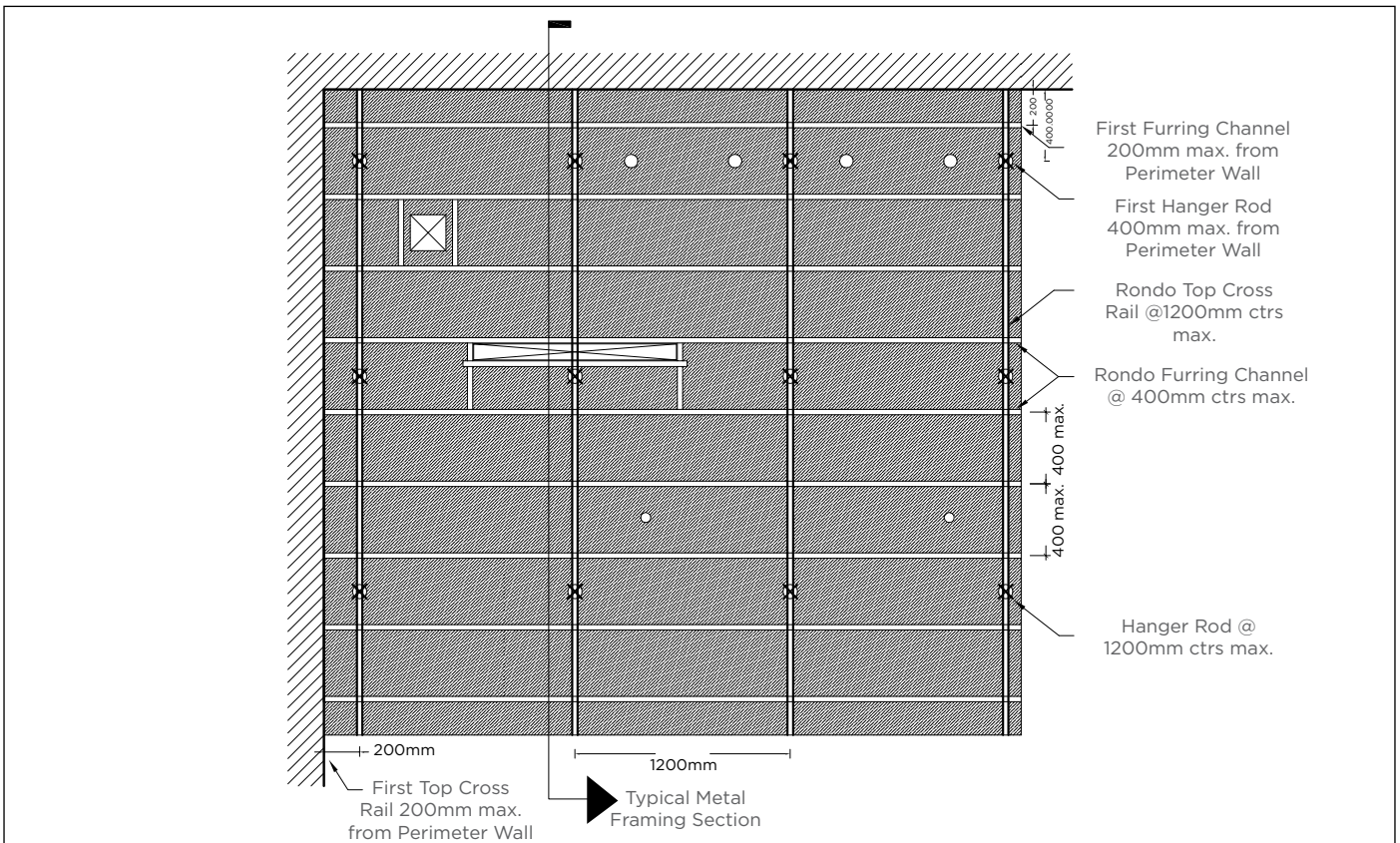

DETAILS

TRANSITION FROM USG BORAL ENSEMBLE™ ACOUSTICAL PLASTERBOARD CEILING TO ACOUSTICAL PANEL CEILING

Plasterboard ceiling suspension system used to frame the USG Boral Ensemble™ Acoustical Plasterboard Ceiling, is fully compatible with USG Donn® Brand DX®/DXL™, Centricitee™ DXT™, Fineline® DXF™, and other USG Boral suspension systems. This makes it easy to transition between flat USG Boral Ensemble™ Acoustical Plasterboard Ceiling and acoustical panel ceilings or plasterboard ceilings. When transitioning to flat plasterboard ceiling areas or bulkheads and soffits, finishing with the USG Boral Ensemble™ Spray-applied Finish creates a seamless and consistent aesthetic.

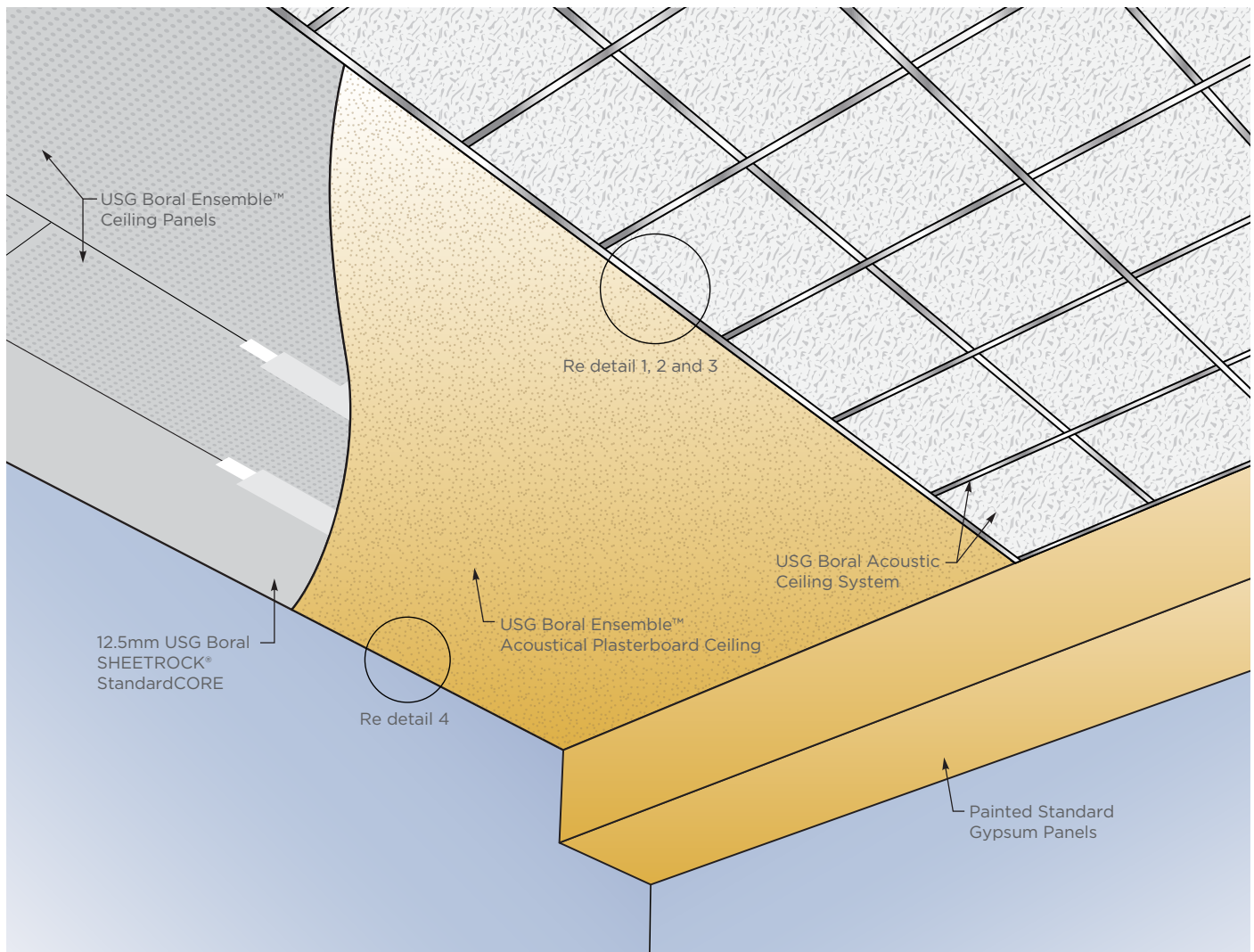

DETAILS

UTILITY INTERFACES AND ACCESS PANELS

The USG Boral Plasterboard suspension system, used to frame the USG Boral Ensemble™ Ceiling Panels, easily accommodates conventional light fixtures, linear light fixtures, access doors or HVAC ceiling diffusers. USG Boral Ensemble™ Spray-applied Finish can be used to coat most primed or painted metal access doors for an improved aesthetic that matches the ceiling.

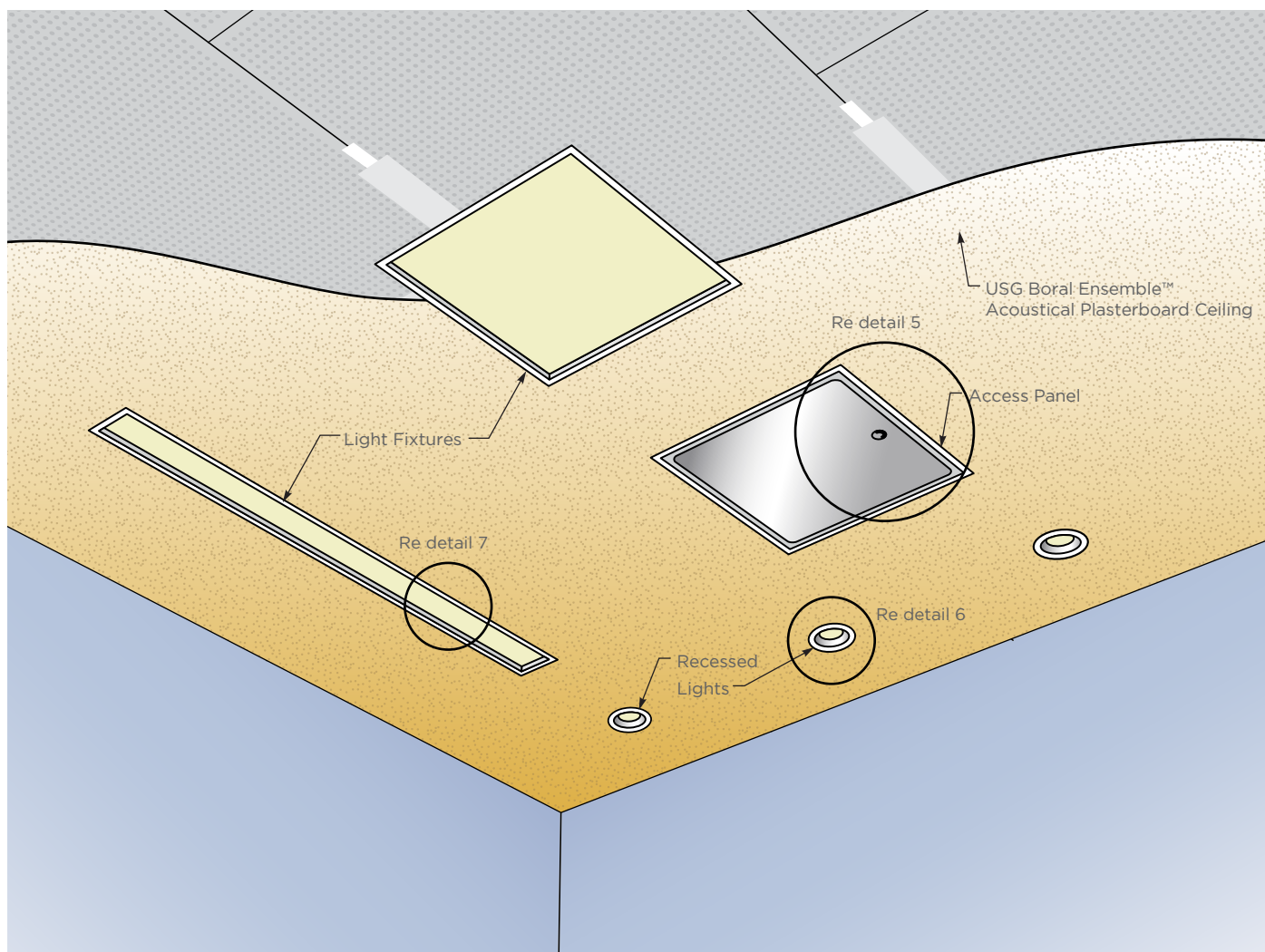

DETAILS

CONTROL JOINTS

Control joints are used to control stress caused by expansion and contraction across the control joint in large ceiling expanses in plasterboard ceiling systems. USG Boral Ensemble™ ceilings have the same requirements for control joints as drywall ceilings. Control joints are needed for USG Boral Ensemble™ ceilings that exceed 12m with perimeter relief, and 9m without perimeter relief. Use continuous secondary runner parallel and on either side of the control joint.

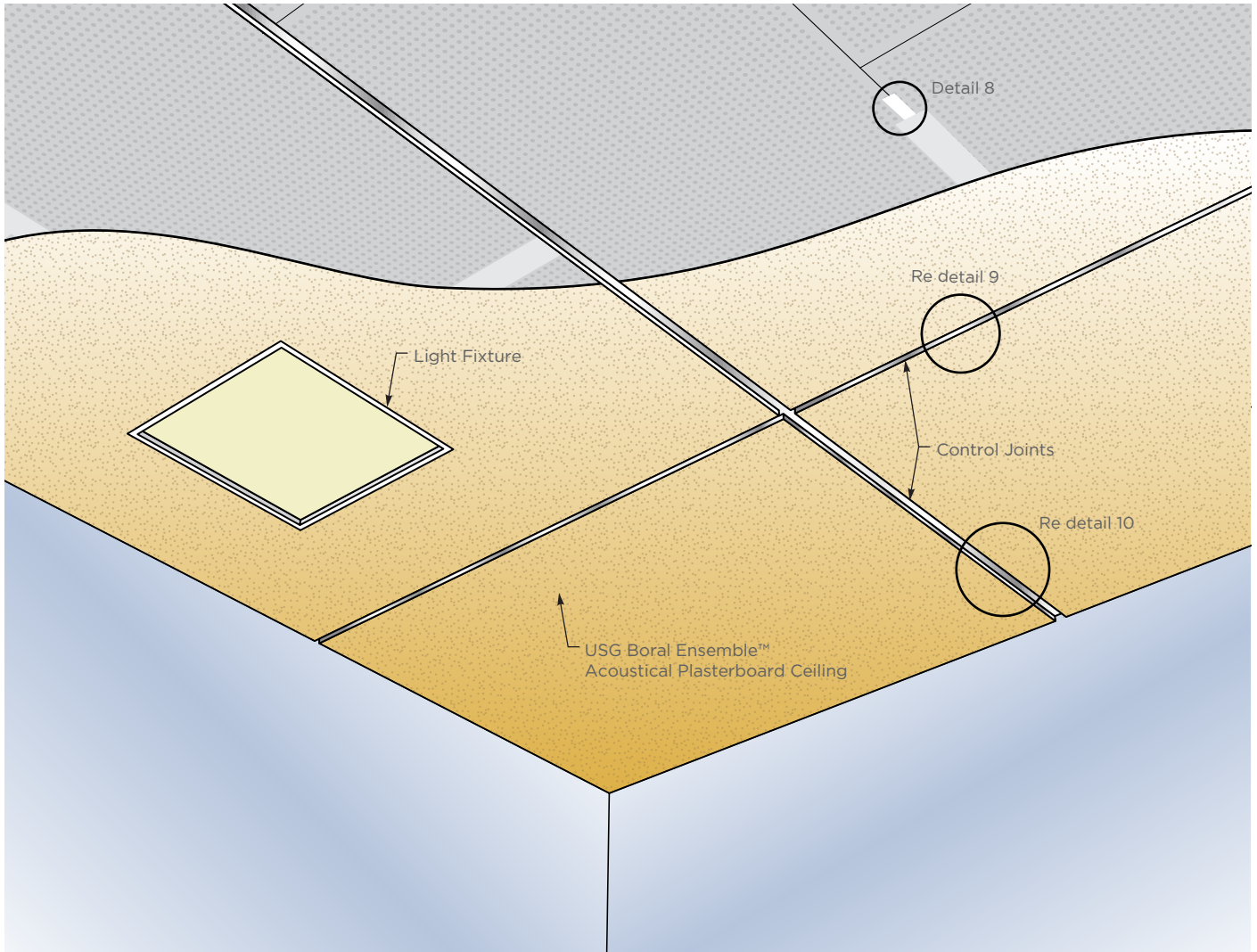

DETAILS

TRANSITION DETAIL

USG Boral Ensemble™ Acoustical Plasterboard Ceiling can transition easily to an acoustical ceiling system.

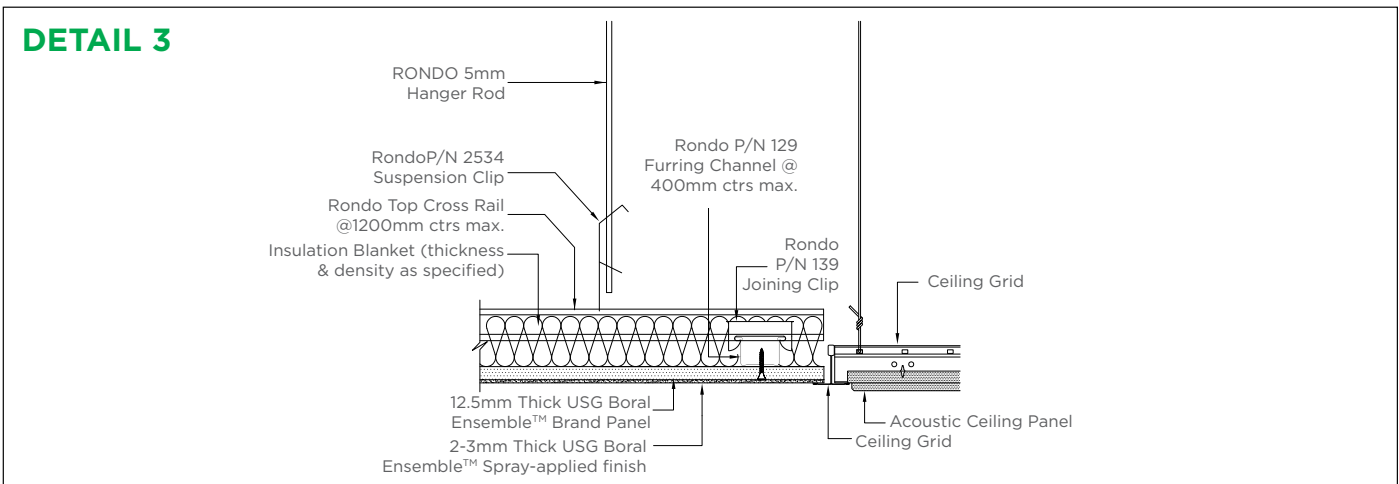
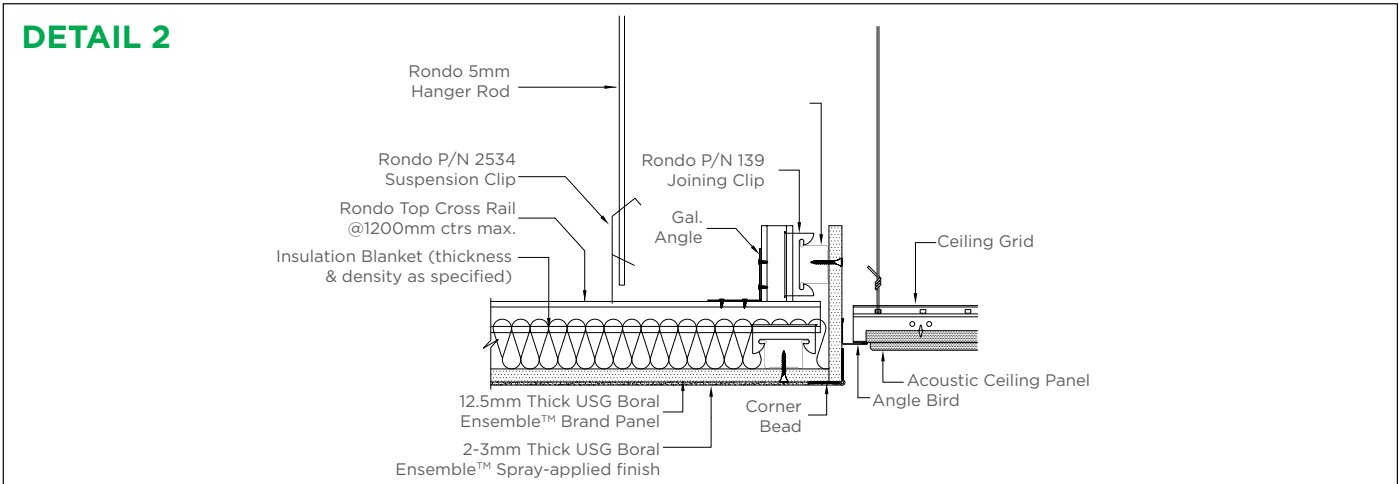
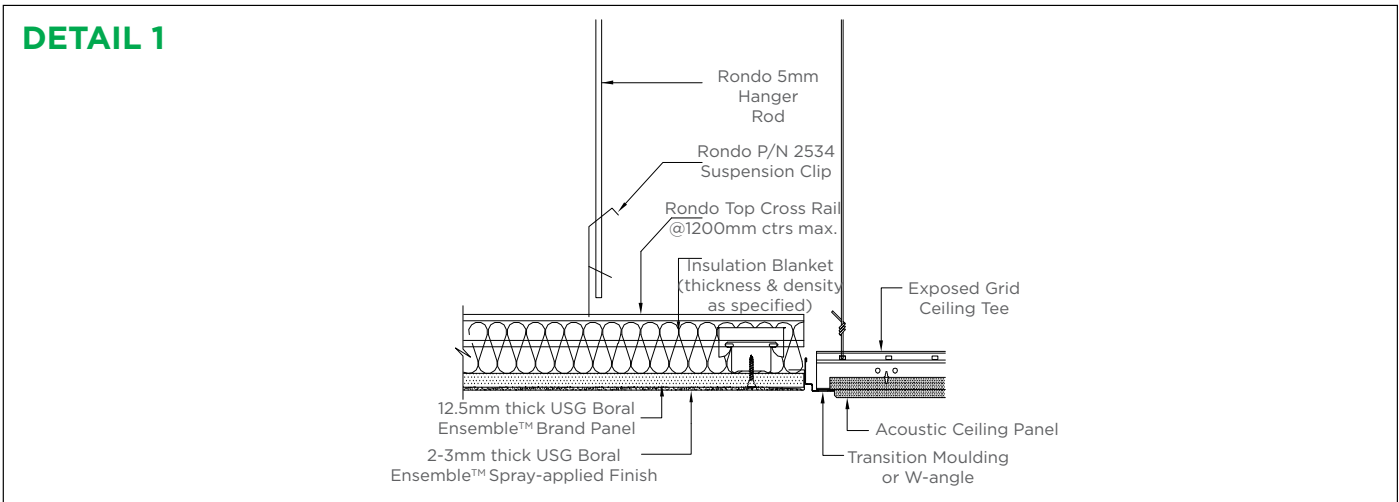

DETAILS

CEILING TO PARTITION TERMINATION WITH PERIMETER RELIEF

Another method of detailing the USG Boral Ensemble™ Acoustical Plasterboard Ceiling is to create a reveal at the perimeter by using a plasterboard L-trim or J-stop. By providing this “perimeter relief” detail, the need for control joints is reduced. Control joints would be needed every 9m without perimeter relief and 12m with perimeter relief.

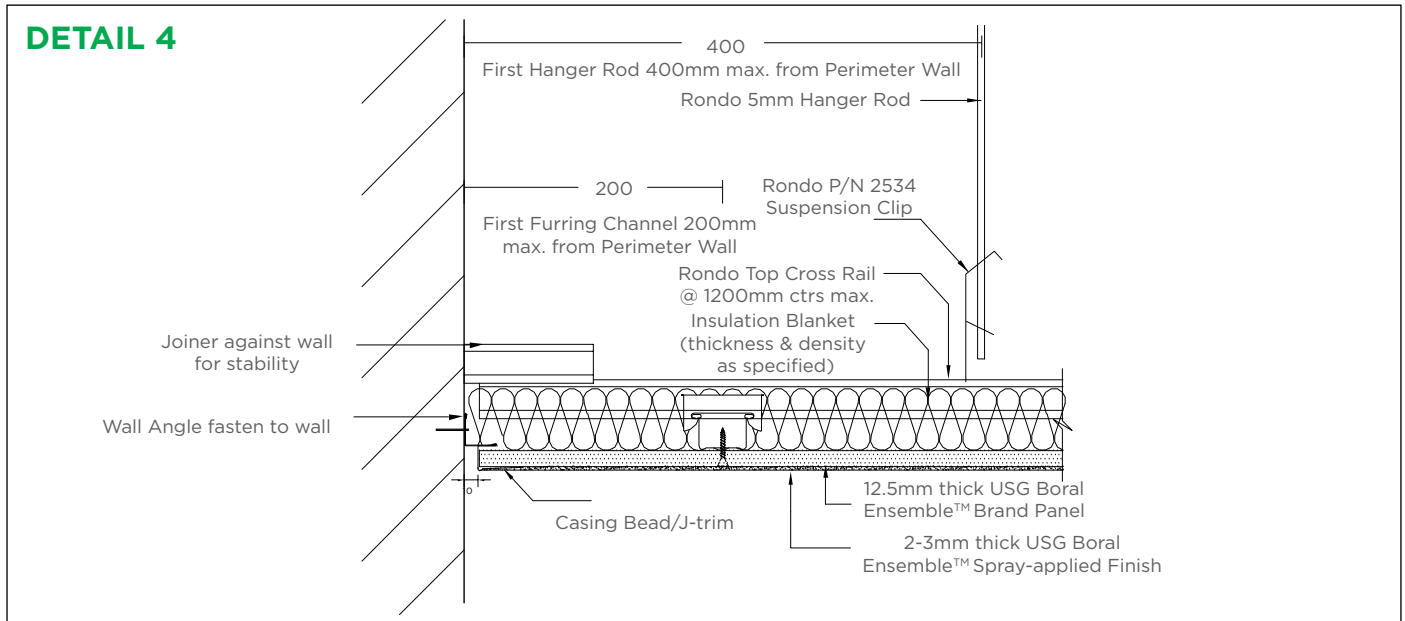

Ceiling to Partition Termination with Perimeter Relief.

ACCESS PANEL DETAIL

Access panels can be installed in USG Boral Ensemble™ Acoustical Plasterboard Ceiling wherever access is needed for electrical junction boxes, etc. Most access panels will work and can be coated directly with the USG Boral Ensemble™ Spray-applied Finish. The best type of access panel for USG Boral Ensemble™ Acoustical Plasterboard Ceiling meets the following criteria:

1. Has a primed or low-sheen painted finish.
2. Is white in colour or is primed or painted white on site before coating.
3. Latch and key access panels work well for reducing damage when opening or closing.

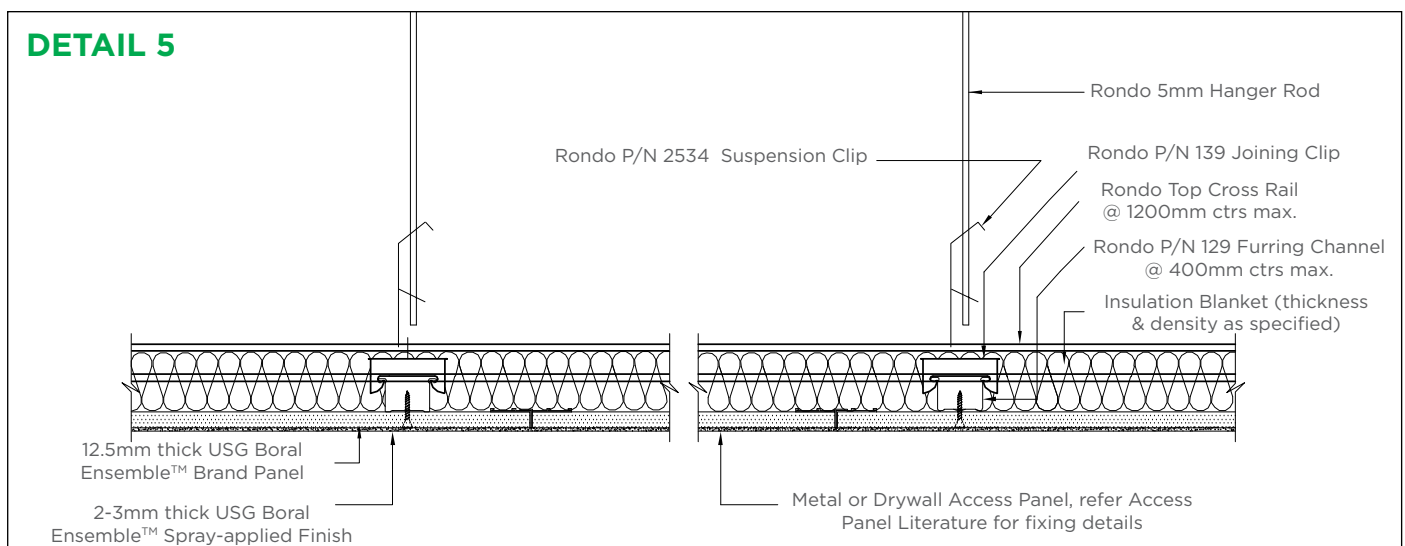

DETAILS

LIGHT FIXTURE OPENING DETAIL

Point light fixtures can integrate easily with USG Boral Ensemble™ Acoustical Plasterboard Ceiling. Either trimless or trimmed fixtures will work.

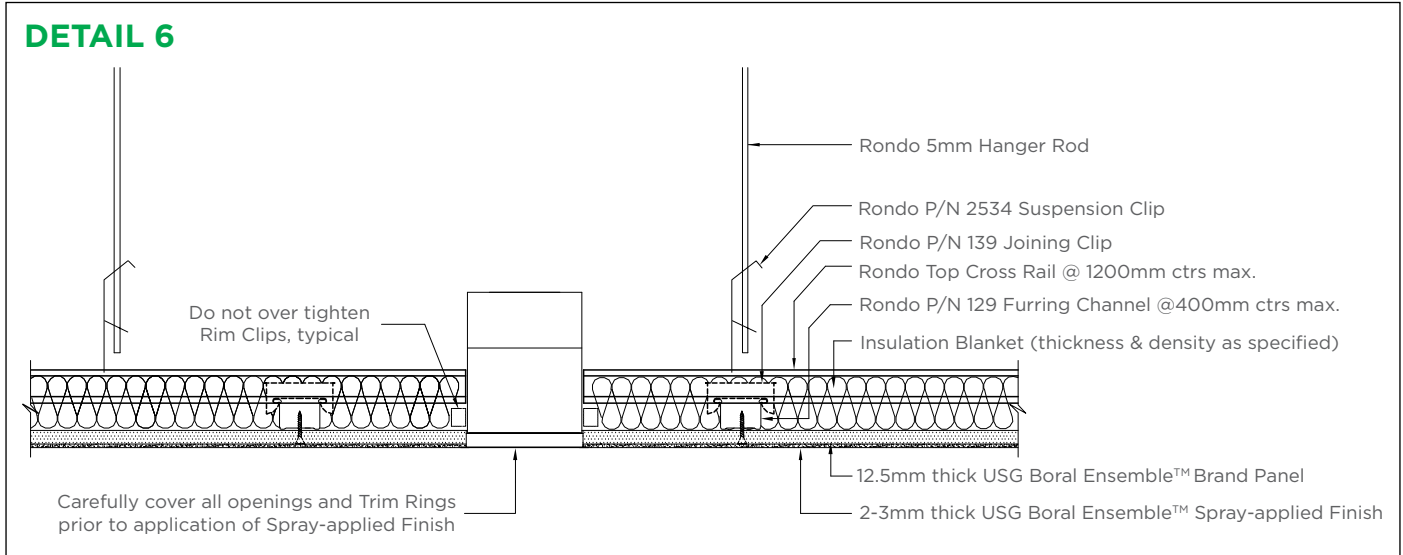

LINEAR OPENING

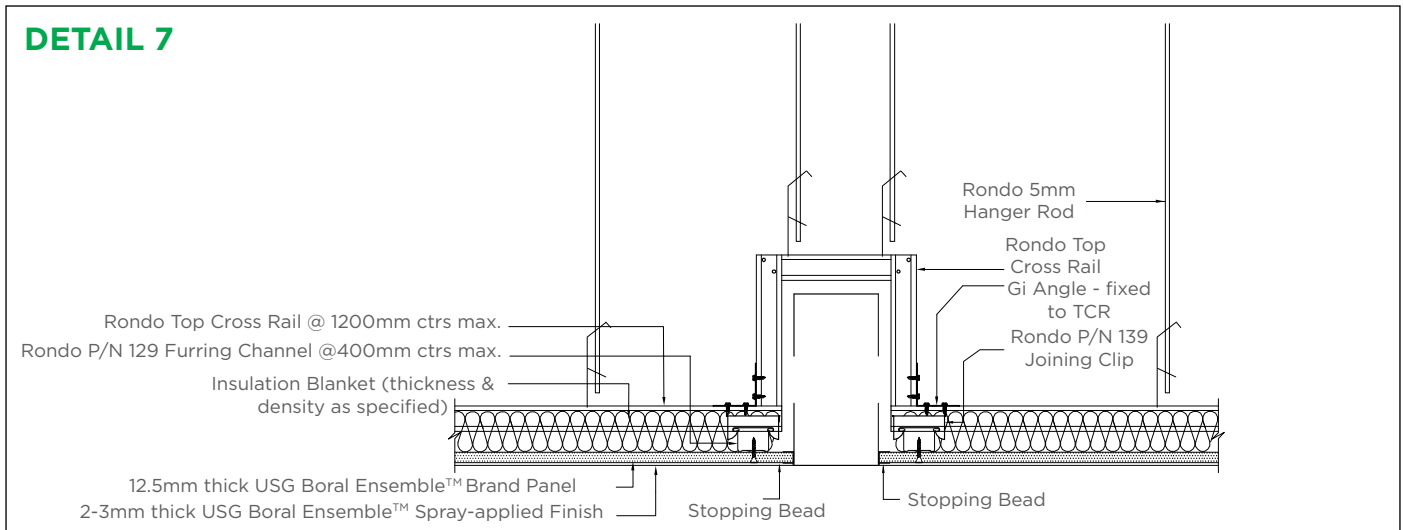

DETAILS

PANEL JOINT DETAIL

The long tapered joints of the USG Boral Ensemble™ Ceiling Panels attach directly to USG Boral Suspension System framing members just like a plasterboard ceiling.

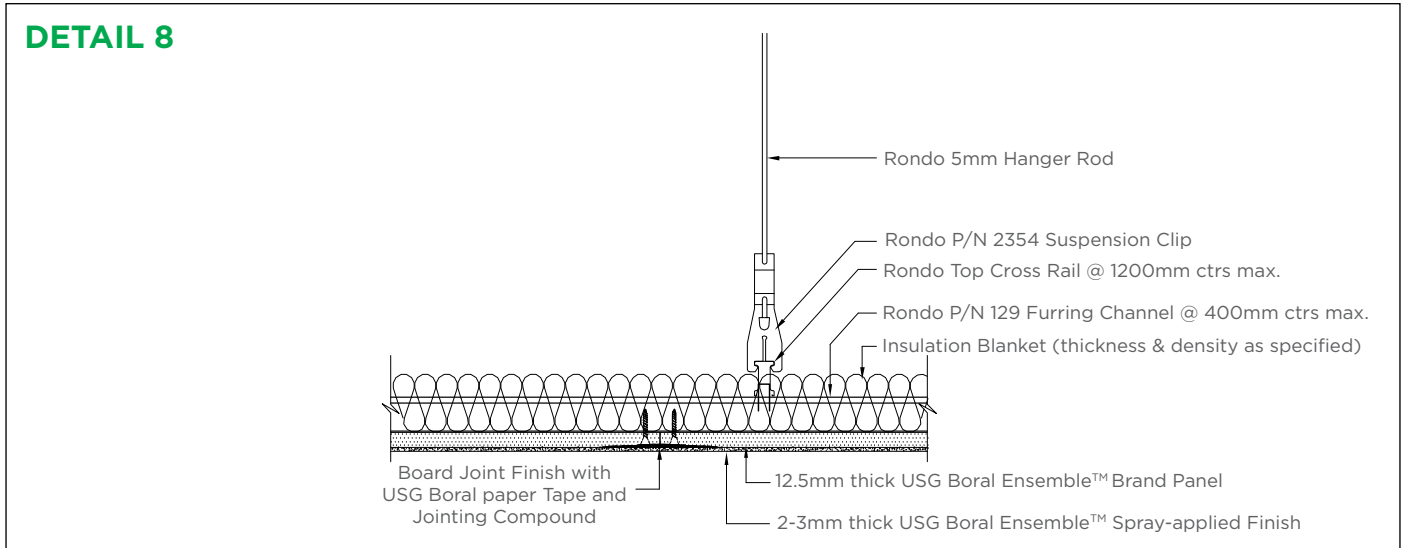

TYPICAL CONTROL JOINT

Control joint requirements for USG Boral Ensemble™ Acoustical Plasterboard Ceiling are the same as for plasterboard ceilings: Every 9m without perimeter relief. With perimeter relief, every 12m.

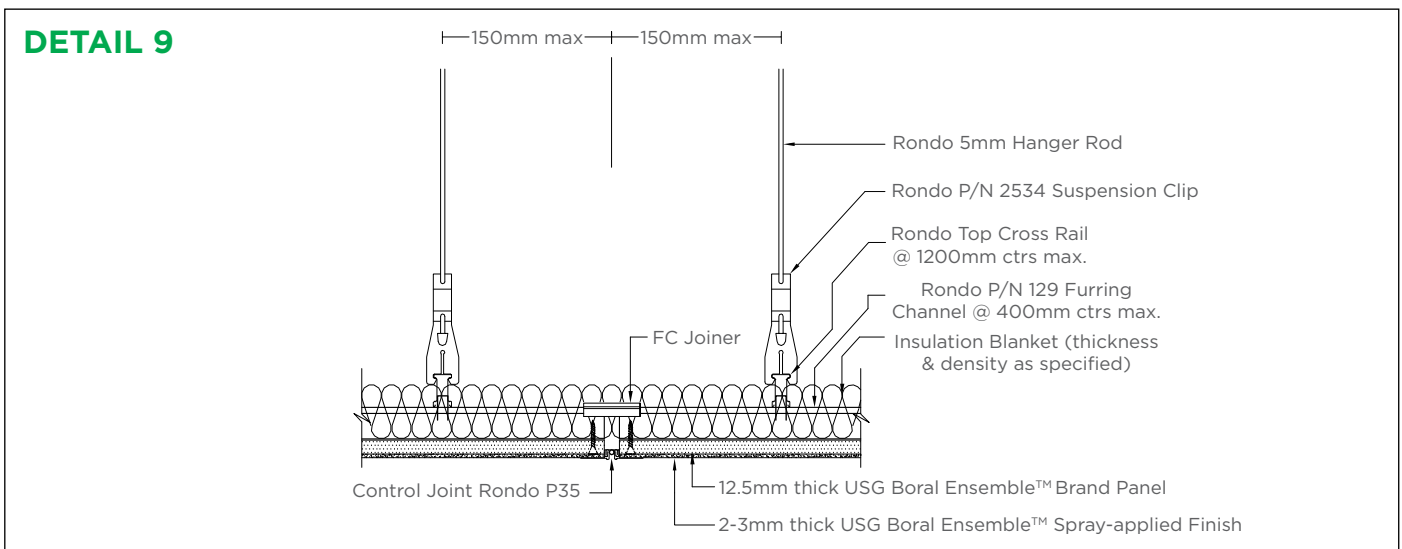

DETAILS

ALTERNATIVE CONTROL JOINT

Ideally control joints should include a break in the framing. Here, secondary framing run parallel with a small separation to fit the control joint. Control joint requirements for USG Boral Ensemble™ Acoustical Plasterboard Ceiling are the same as for plasterboard ceilings: Every 9m without perimeter relief. With perimeter relief, every 12m.

DETAIL 9a

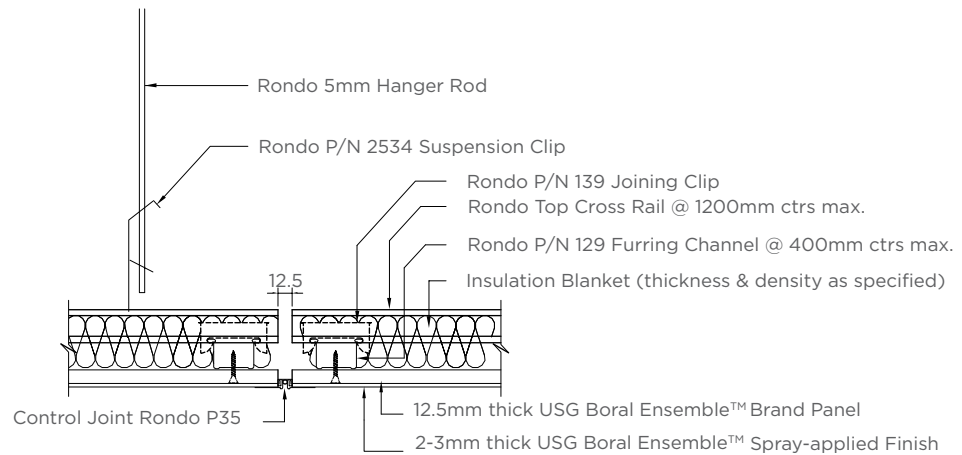

Special Note: Location of control and expansion joints are the responsibility of the design professional. USG Boral Plasterboard surfaces should be isolated with control joints, caulk or other means where:

- Ceiling or soffit abuts a structural element, column, partition or other vertical penetration.
- Construction changes within a plane of the ceiling.
- Ceiling dimensions exceed 15m in either direction (232 sq mtr) with perimeter relief or 9m (83 sq mtr) without relief.
- Soffit exceeds 9m in either direction.
- Wings of “L”, “U” and “T” shaped ceilings areas are joined.

TYPICAL REVEAL TRIM INSTALLATION

Reveal trims can easily be integrated with USG Boral Ensemble™ Acoustical Plasterboard Ceiling to create a unique aesthetic.

DETAIL 10

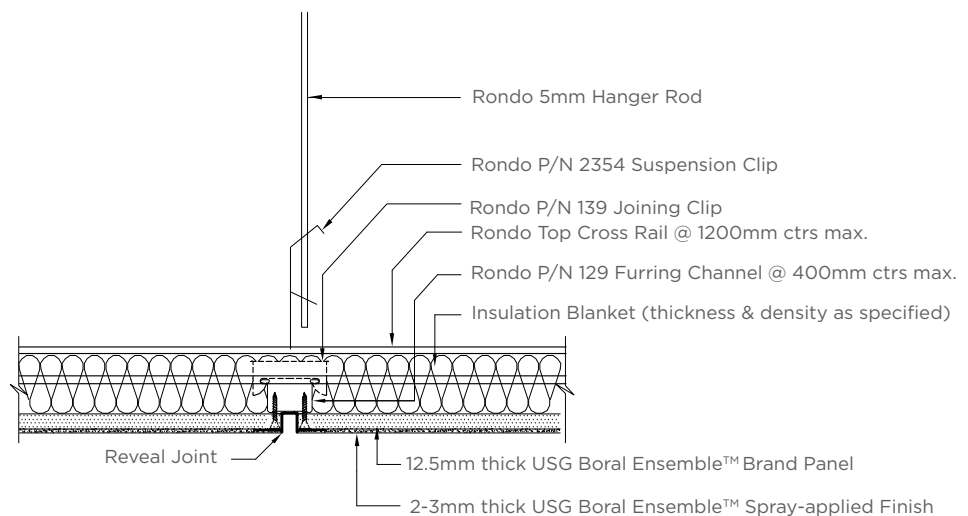

OTHER COMMON DETAILS

CEILING TO PARTITION TERMINATION WITH FINISHED CORNER

One method of finishing the USG Boral Ensemble™ Acoustical Plasterboard Ceiling is to use a corner bead for a neat and straight finished corner.

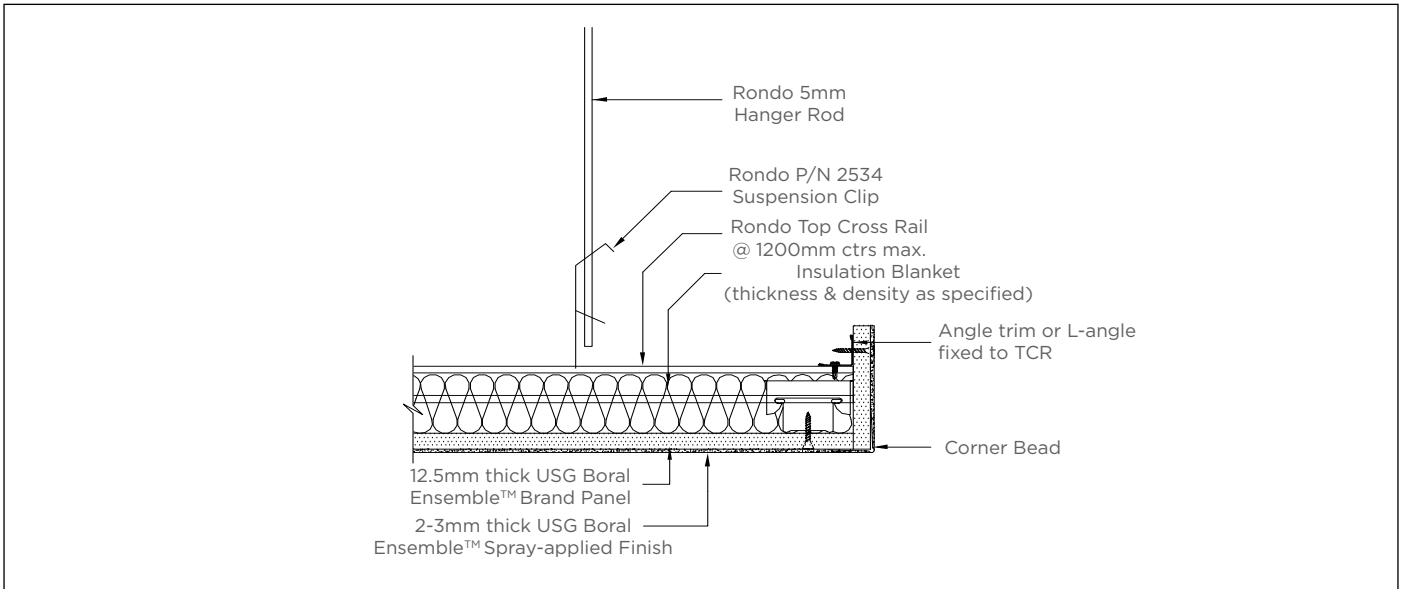

SPRINKLER DETAIL

Sprinkler heads integrate with USG Boral Ensemble™ Acoustical Plasterboard Ceiling the same way as with a plasterboard ceiling.

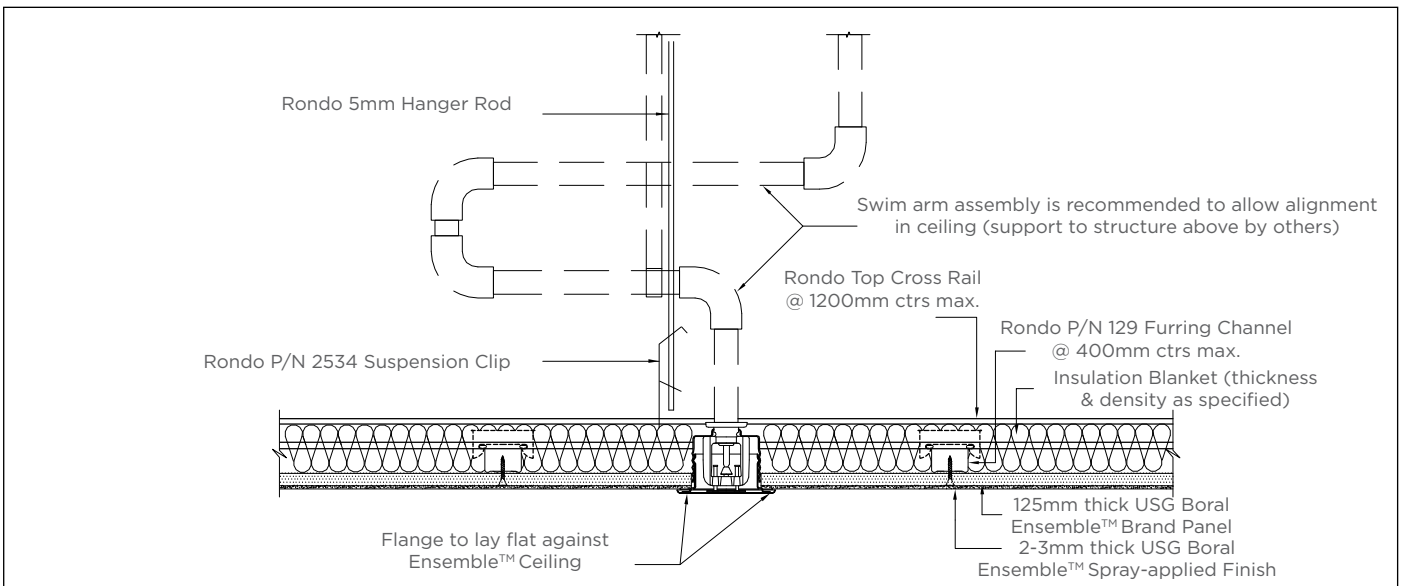

Australia
China
India
Indonesia
Malaysia
Middle East
New Zealand
Philippines
Singapore
South Korea
Thailand
Vietnam

USG Boral Pte Ltd

8 Boon Lay Way #02-06

TradeHub 21

Singapore 609964

Tel: (65) 6272 9272

Fax: (65) 6278 5310

Email: contact-us.sg@usgboral.com