

Boral CinemaZone™ Fact Sheet



Construction

CinemaZone™ Internal wall - plan view

- new building
- single stud wall

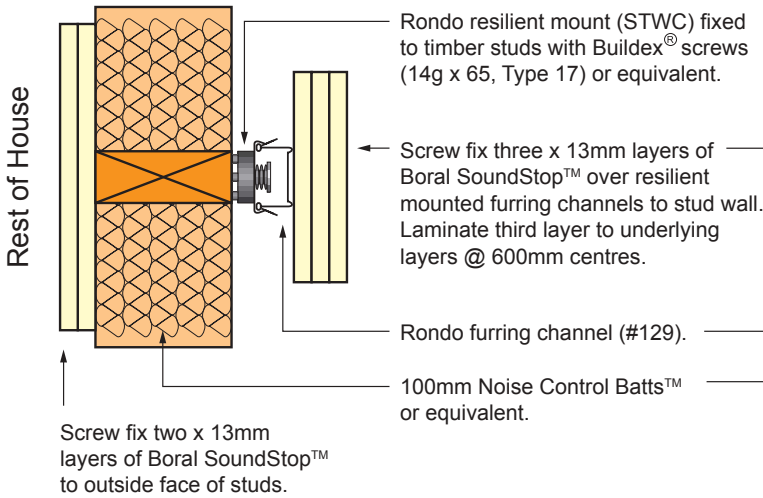

- existing building
- single stud wall

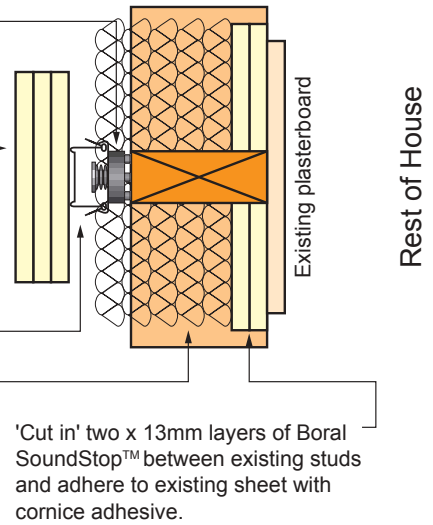

- new building
- double stud wall

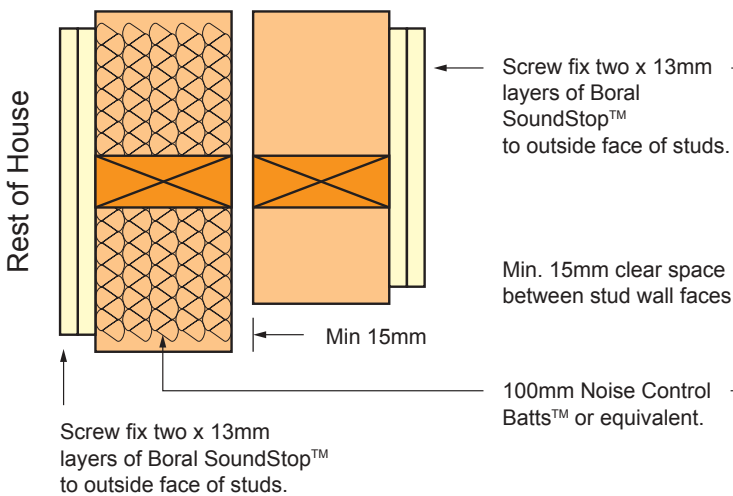

- existing building
- double stud wall

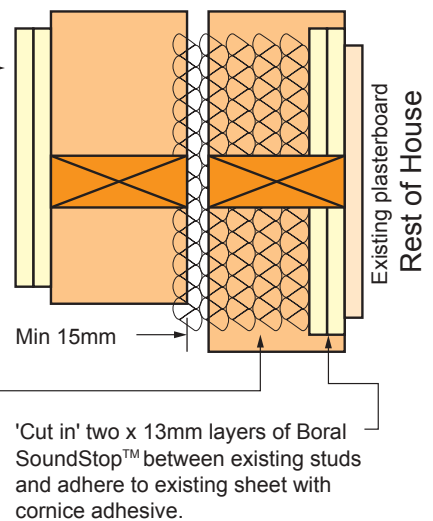

Boral CinemaZone™ Fact Sheet



Construction

CinemaZone™ wall details

- CinemaZone™ brick veneer wall
- plan view

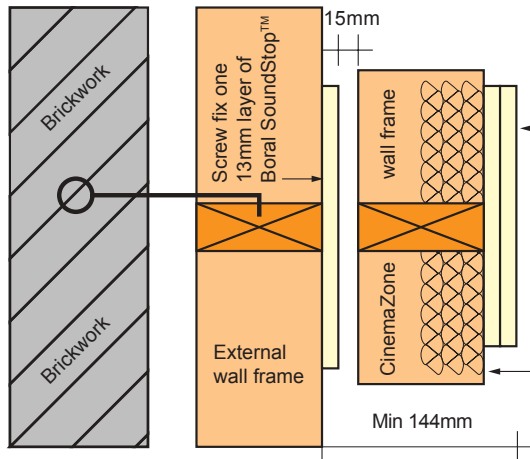

- CinemaZone™ / Boral FireLight™
Internal wall - plan view*

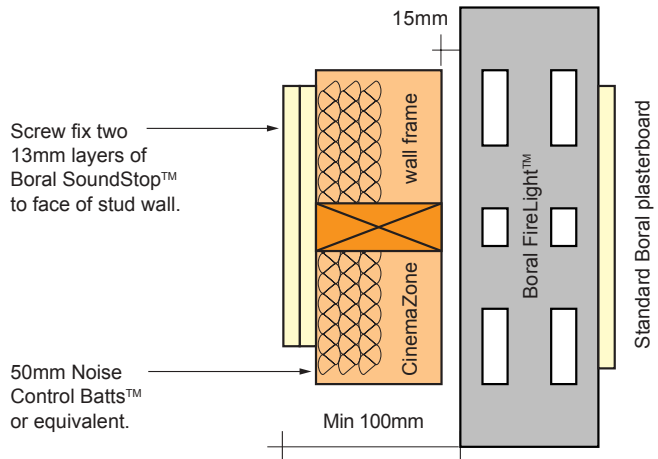

- CinemaZone™ wall junction
- plan view

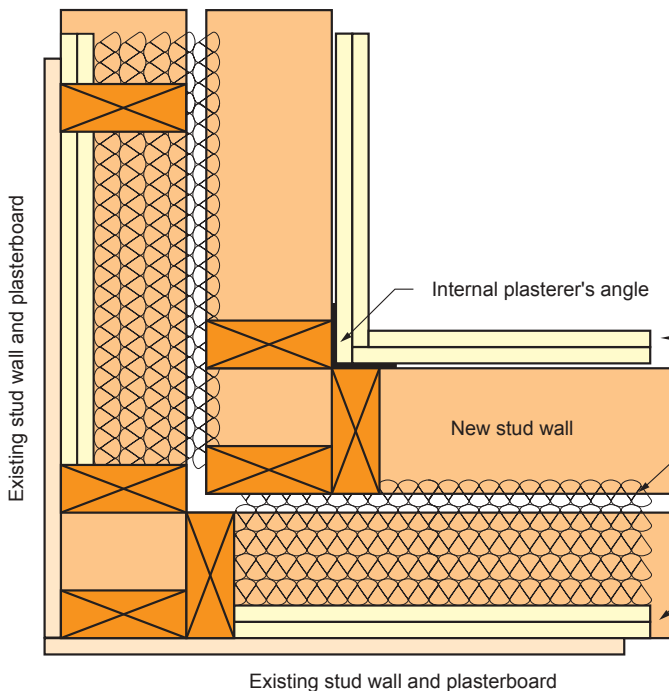

- CinemaZone™ weatherboard wall
- plan view

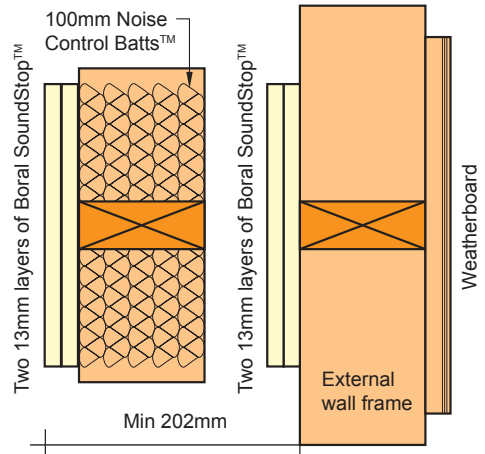

Screw fix two 13mm layers of Boral SoundStop™ to face of stud wall.

100mm Noise Control Batts™ or equivalent.

Min. 15mm clear space between wall frames.

*'Cut in' two x 13mm layers of Boral SoundStop™ between existing studs and adhere to back of existing sheet with cornice adhesive.

* WA customers should contact Midland Brick for the appropriate product in the 'Special Performance' brick range.



Boral CinemaZone™ Fact Sheet



Construction

CinemaZone™ Internal wall - section view

- existing building
- double stud wall option

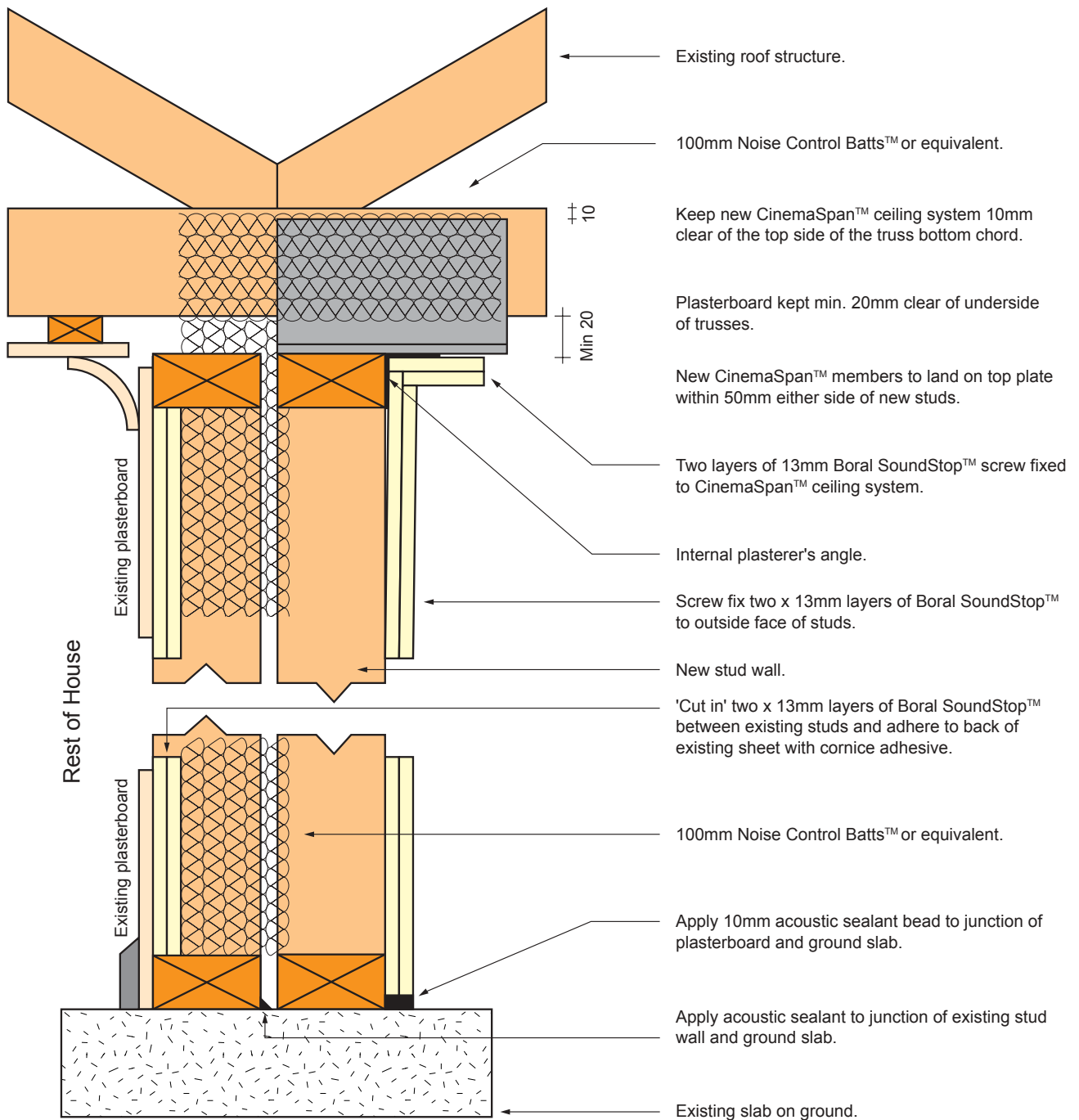

Boral CinemaZone™ Fact Sheet



Construction

CinemaZone™ Ceiling - section view

- new and existing buildings
- resilient mounted furring channel option

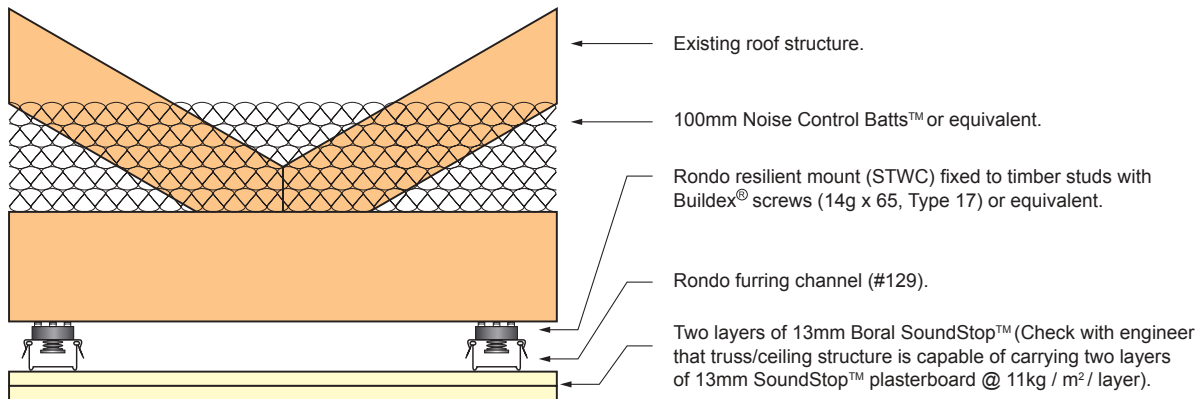

- new and existing buildings
- separate ceiling support system

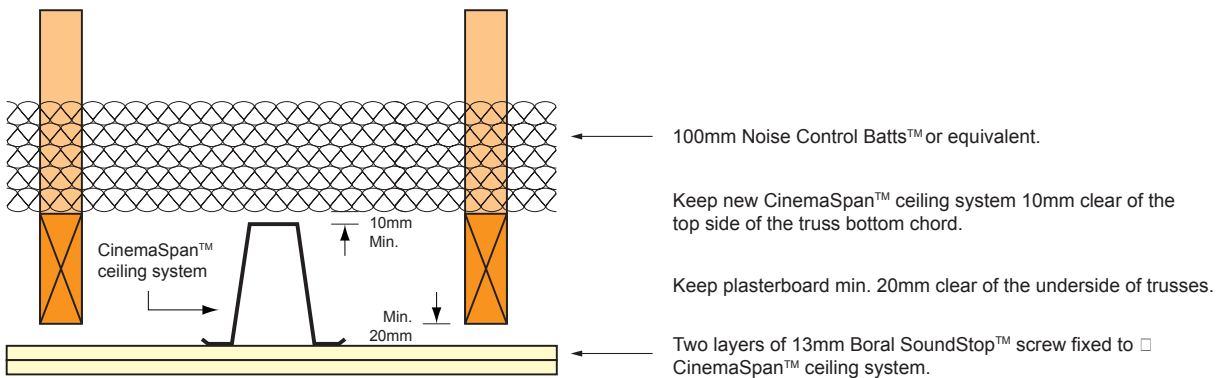

Screws - Plasterboard to Framing

Number and thickness of plasterboard layers	Timber Frame Type W Screws	Steel Frame Type S or Type D Screws
1 x 13mm	6 - 9 x 32mm	6 - 18 x 25mm*
2 x 13mm	6 - 9 x 50mm	6 - 18 x 40mm
3 x 13mm	8 - 8 x 60mm	7 - 16 x 50mm Type S only

Screw identification is given as: (min. gauge) - (threads/inch + 1) x (min. length).
 * For ease of construction use min. 30mm length screws on steel framing with a gauge less than 0.8mm BMT.

Screws - Plasterboard to Plasterboard

Number and thickness of plasterboard layers		Type L Screws for fixing plasterboard
Plasterboard A	Plasterboard B	A to B
1 x 13mm	Min. 13mm	10 - 8 x 32mm

Screw identification is given as:
 (min. gauge) - (threads/inch + 1) x (min. length).



Boral CinemaZone™ Fact Sheet



Construction

CinemaZone™ Construction details

• CinemaZone™ wall vent - section view

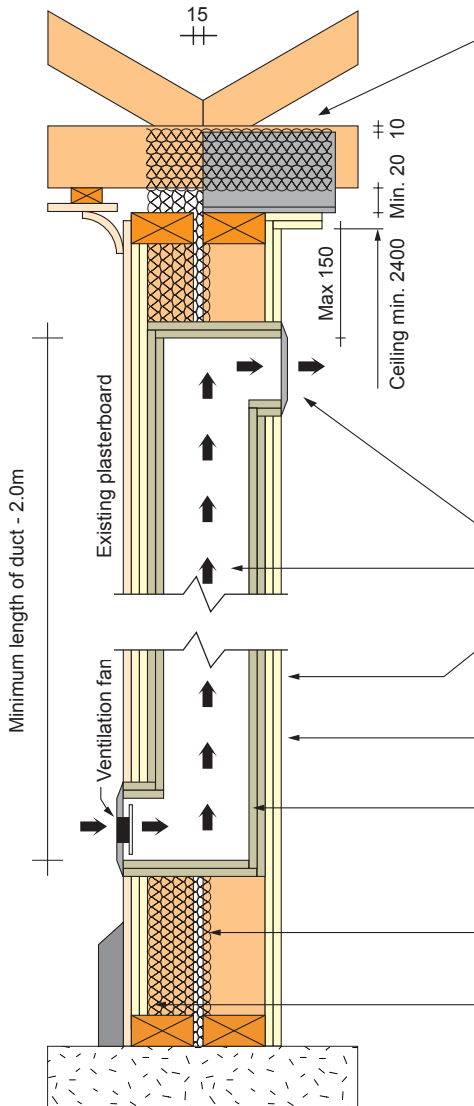

Inlet vent requires fan assistance. Fan assistance is optional for the exhaust vent.

100mm Noise Control Batts™ or equivalent.

Keep CinemaSpan™ ceiling system 10mm clear of the top side of the truss bottom chord.

Keep plasterboard min. 20mm clear of underside of truss.

Internal plasterer's angle behind wall & ceiling junctions.

Min. ceiling height = 2400mm
Consult local building authority before proceeding if a lower ceiling is required.

Keep min. 15mm clear space between stud wall faces.

Ventilation Grill.

Min. internal duct cross-section equivalent to 200mm x 100mm.

Screw fix two x 13mm layers of Boral SoundStop™ to outside face of studs.

Remove nogging between studs to allow passage of duct.

Ventilation duct lined with two layers of sound absorbent material, such as NoiseStop™ board or equivalent.

100mm Noise Control Batts™ or equivalent.

'Cut in' two x 13mm layers of Boral SoundStop™ between existing studs and adhere to back of existing sheet with cornice adhesive.

• CinemaZone™ window - plan view

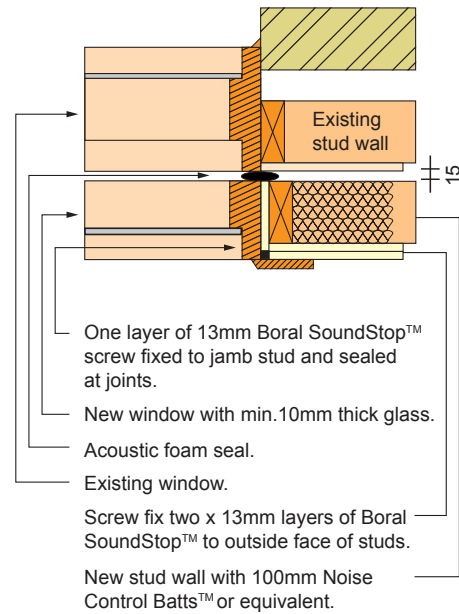

One layer of 13mm Boral SoundStop™ screw fixed to jamb stud and sealed at joints.

New window with min. 10mm thick glass.

Acoustic foam seal.

Existing window.

Screw fix two x 13mm layers of Boral SoundStop™ to outside face of studs.

New stud wall with 100mm Noise Control Batts™ or equivalent.

Boral recommends fitting a CinemaZone™ home cinema with at least one fan-assisted inlet vent and one exhaust vent. □
The inlet vent should draw air from an adjoining habitable room or from the outside. It should not draw air from a kitchen, bathroom, toilet or laundry or a room that CinemaZone™ air is being exhausted into. The exhaust ventilation duct (fan optional), similar to the one shown, may also be fitted to the ceiling. □
Boral suggests home cinemas achieve at least 6 air changes per hour, however, this will depend on the volume of the room and the number of people intended to use it. □ Larger installations may require the advice of an air-conditioning professional. □

• CinemaZone™ doorway - plan view

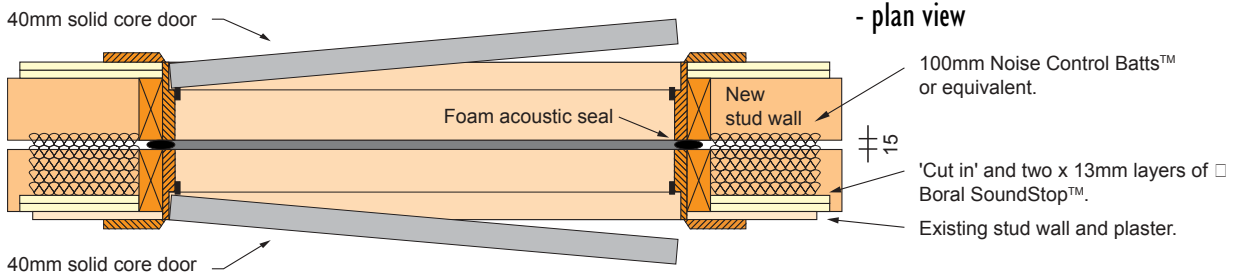

100mm Noise Control Batts™ or equivalent.

'Cut in' and two x 13mm layers of Boral SoundStop™.

Existing stud wall and plaster.

Fit acoustic seals to both door frames, Raven #RP94Si to door head and jambs and Raven #RP8 to sill, or equivalent. Maintain 15mm gap between door frames.



NB: CinemaZone™ and CinemaSpan™ are trademarks of Boral Plasterboard.

Boral CinemaZone™ Fact Sheet



Construction

CinemaZone™ Wall and ceiling penetrations

• powerpoint wall penetration - section view

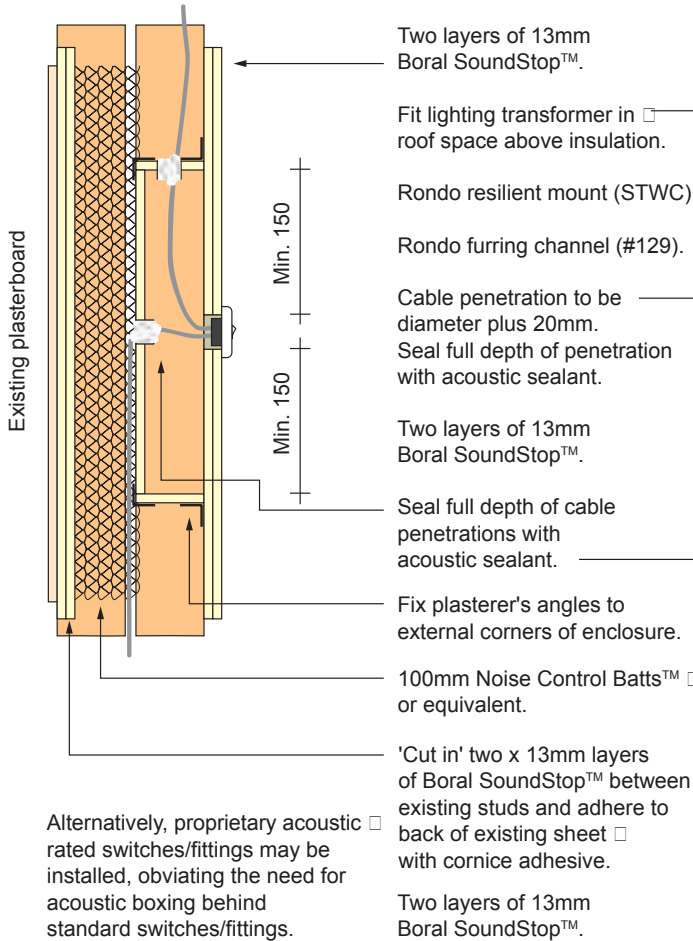

• light fitting ceiling penetration - section view

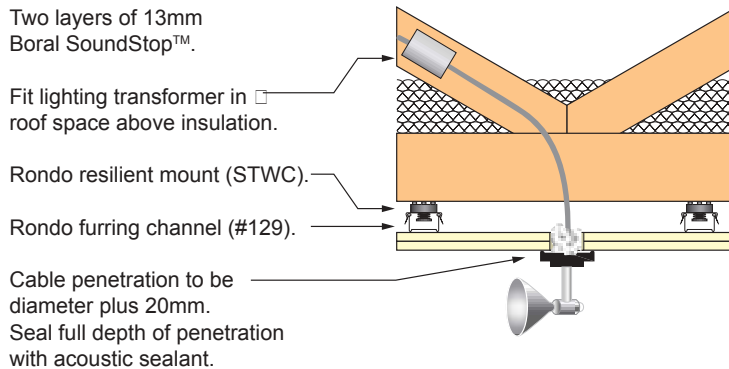

• powerpoint wall penetration - plan view

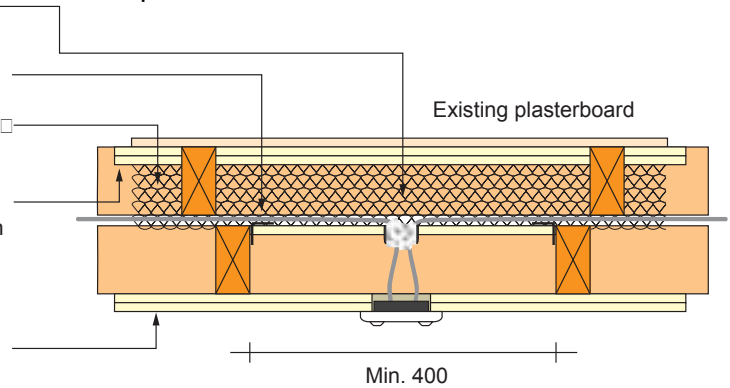

For more information on CinemaZone™ or to request the other free fact sheets in this series, call Boral Plasterboard TecASSIST on 1800 811 222 for a fax or email copy or visit the website:

www.boral.com.au/cinemazone

Performance



Sound advice

- How Boral CinemaZone™ works
- Sound and Noise levels
 - * Who it affects
 - * How to control it
- The 'Sweet Spot'

Design



Details to consider

- Sound coming in
- Sound going out
- Room dimensions
- Lighting
- Ventilation

